

GATE: 2007
CE: CIVIL ENGINEERING

Q.1 – Q-20 Carry One Mark Each

1. The minimum and the maximum Eigen values of the matrix $\begin{bmatrix} 1 & 1 & 3 \\ 1 & 5 & 1 \\ 3 & 1 & 1 \end{bmatrix}$ are -2 and 6, respectively.
What is the other Eigen value?
(A) 5 (C) 1
(B) 3 (D) -1
2. The degree of the differential equation $\frac{d^2x}{dt^2} + 2x^3 = 0$ is
(A) 0 (C) 2
(B) 1 (D) 3
3. The solution for the differential equation $\frac{dy}{dx} = x^2y$ with condition that $y = 1$ at $x = 0$ is
(A) $y = e^{\frac{1}{2x}}$ (C) $\ln(y) = \frac{x^2}{2}$
(B) $\ln(y) = \frac{x^3}{3} + 4$ (D) $y = e^{\frac{x^3}{3}}$
4. An axially loaded bar is subjected to a normal stress of 173 MPa. The shear stress in the bar is
(A) 75 MPa (C) 100 MPa
(B) 86.5 MPa (D) 122.3 MPa
5. A steel column, pinned at both ends, has a buckling load of 200 kN. If the column is restrained against lateral movement at its mid-height, its buckling load will be
(A) 200 kN (C) 400 kN
(B) 283 kN (D) 800 kN
6. The stiffness coefficient k_{ij} indicates
(A) Force at i due to a unit deformation at j. (C) Deformation at i due to a unit force at j.
(B) Deformation at j due to a unit force at i. (D) Force at j due to a unit deformation at i.

7. For an isotropic material, the relationship between the Young's modulus (E), shear modulus (G) and Poisson's ratio (μ) is given by

$$(A) G = \frac{E}{2(1+\mu)}$$

$$(C) G = \frac{E}{(1+2\mu)}$$

$$(B) E = \frac{G}{2(1+\mu)}$$

$$(D) G = \frac{E}{2(1-\mu)}$$

8. A clay soil sample is tested in triaxial apparatus in consolidated-drained conditions at a cell pressure of 100 kN/m^2 . What will be the pore water pressure at a deviator stress of 40 kN/m^2 ?

$$(A) 0 \text{ kN/m}^2$$

$$(C) 40 \text{ kN/m}^2$$

$$(B) 20 \text{ kN/m}^2$$

$$(D) 60 \text{ kN/m}^2$$

9. The number of blows observed in a Standard Penetration Test (SPT) for different penetration depths are given as follows.

Penetration of sampler	Number of blows
0 – 150 mm	6
150 – 300 mm	8
300 – 450 mm	10

The observed N value is

$$(A) 8$$

$$(C) 18$$

$$(B) 14$$

$$(D) 24$$

10. The vertical stress at some depth below the corner of a $2 \text{ m} \times 3 \text{ m}$ rectangular footing due to a certain load intensity is 100 kN/m^2 below the centre of a $4 \text{ m} \times 6 \text{ m}$ rectangular footing at the same depth and same load intensity?

$$(A) 25$$

$$(C) 200$$

$$(B) 100$$

$$(D) 400$$

11. There is a free overfall at the end of a long open channel. For a given flow rate, the critical depth is less than the normal depth. What gradually varied flow profile will occur in the channel for this flow rate?

$$(A) M_1$$

$$(C) M_3$$

$$(B) M_2$$

$$(D) S_1$$

12. The consumptive use of water for a crop during a particular stage of growth is 2.0 mm/day . The maximum depth of available water in the root zone is 60 mm . Irrigation is required when the

- amount of available water is 50% of the maximum available water in the root zone. Frequency of irrigation should be
- (A) 10 days (C) 20 days
(B) 15 days (D) 25 days
13. As per the Lacey's method for design of alluvial channels, identify the true statement from the following
- (A) Wetted perimeter increases with an increase in design discharge
(B) Hydraulic radius increases with an increase in silt factor.
(C) Wetted perimeter decreases with an increase in design discharge.
(D) Wetted perimeter increases with an increase in silt factor.
14. At two points 1 and 2 in a pipeline the velocities are V and $2V$, respectively. Both the points are at the same elevation. Both the points are at the same elevation. The fluid density is ρ . The flow can be assumed to be incompressible, inviscid, steady and irrotational. The difference in pressures P_1 and P_2 at points 1 and 2 is
- (A) $0.5 \rho V^2$ (C) $2 \rho V^2$
(B) $1.5 \rho V^2$ (D) $3 \rho V^2$
15. The presence of hardness in excess of permissible limit causes
- (A) Cardio Vascular problems (C) Calcium deficiency
(B) Skin discolouration (D) Increased laundry expenses
16. The dispersion of pollutants in atmosphere is maximum when
- (A) Environmental lapse rate is greater than adiabatic lapse rate.
(B) Environmental lapse rate is less than adiabatic lapse rate.
(C) Environmental lapse rate is equal to adiabatic lapse rate.
(D) Maximum mixing depth is equal to zero.
17. The alkalinity and the hardness of a water sample are 250 mg/L and 350 mg/L as CaCO_3 , respectively. The water has
- (A) 350 mg/L carbonate hardness and zero non-carbonate hardness.
(B) 250 mg/L carbonate hardness and zero non-carbonate hardness.
(C) 250 mg/L carbonate hardness and 350 mg/L non-carbonate hardness.
(D) 250 mg/L carbonate hardness and 100 mg/L non-carbonate hardness.

18. The consistency and flow resistance of bitumen can be determined from the following.
- (A) Ductility test (C) Softening point Test
(B) Penetration test (D) Viscosity test
19. If a two-lane national highway and a two-lane state highway intersect at right angles, the number of potential conflict points at the intersection, assuming that both the roads are two – way is
- (A) 11 (C) 24
(B) 17 (D) 32
20. In signal design as per Indian Roads Congress specifications, if the sum of the ratios of normal flows to saturation flow of two directional traffic flow is 0.50 and the total lost time per cycle is 10 seconds, the optimum cycle length in seconds is
- (A) 100 (C) 60
(B) 80 (D) 40

Q.21 to Q.75 carry two marks each

21. For what values of α and β the following simultaneous equations have an infinite number of solutions?
- $$x + y + z = 5; \quad x + 3y + 3z = 9;$$
- $$x + 2y + \alpha z = \beta$$
- (A) 2,7 (C) 8,3
(B) 3,8 (D) 7,2
22. A velocity vector is given as
- $$\vec{V} = 5xy \vec{i} + 2y^2 \vec{j} + 3yz^2 \vec{k}.$$
- The divergence of this velocity vector at (1, 1, 1) is
- (A) 9 (C) 14
(B) 10 (D) 15
23. A body originally at 60°C cools down to 40°C in 15 minutes when kept in air at a temperature of 25°C. What will be the temperature of the body at the end of 30 minutes?
- (A) 35.2°C (C) 28.7°C
(B) 31.5°C (D) 15°C
24. The following equation needs to be numerically solved using the Newton-Raphson method.
- $$x^3 + 4x - 9 = 0$$
- The iterative equation for this purpose is (k indicates the iteration level)

- (A) $x_{k+1} = \frac{2x_k^3+9}{3x_k^2+4}$ (C) $x_{k+1} = x_k - 3x_k^2 + 4$
(B) $x_{k+1} = \frac{3x_k^2+4}{2x_k^2+9}$ (D) $x_{k+1} = \frac{4x_k^2+3}{9x_k^2+2}$
25. Evaluate $\int_0^{\infty} \frac{\sin t}{t} dt$
(A) π (C) $\frac{\pi}{4}$
(B) $\frac{\pi}{2}$ (D) $\frac{\pi}{3}$
26. Potential function ϕ is given as $\phi = x^2 + y^2$. What will be the stream function (ψ) with the condition $\psi = 0$ at $x = y = 0$?
(A) $2xy$ (C) $x^2 - y^2$
(B) $x^2 + y^2$ (D) $2x^2y^2$
27. The inverse of the 2×2 matrix $\begin{bmatrix} 1 & 2 \\ 5 & 7 \end{bmatrix}$ is
(A) $\frac{1}{3} \begin{bmatrix} -7 & 2 \\ 5 & -1 \end{bmatrix}$ (C) $\frac{1}{3} \begin{bmatrix} 7 & -2 \\ -5 & 1 \end{bmatrix}$
(B) $\frac{1}{3} \begin{bmatrix} 7 & 2 \\ 5 & 1 \end{bmatrix}$ (D) $\frac{1}{3} \begin{bmatrix} -7 & -2 \\ -5 & -1 \end{bmatrix}$
28. Given that one root of the equation $x^3 - 10x^2 + 31x - 30 = 0$ is 5, the other two roots are
(A) 2 and 3 (C) 3 and 4
(B) 2 and 4 (D) -2 and -3
29. If the standard deviation of the spot speed of vehicles in a highway is 8.8 kmph and the mean speed of the vehicles is 33 kmph, the coefficient of variation in speed is
(A) 0.1517 (C) 0.2666
(B) 0.1867 (D) 0.3646
30. A metal bar of length 100 mm is inserted between two rigid supports and its temperature is increased by 10°C . If the coefficient of thermal expansion is 12×10^{-6} per $^\circ\text{C}$ and the Young's modulus is 2×10^5 MPa, the stress in the bar is
(A) Zero (C) 24 MPa
(B) 12 MPa (D) 2400 MPa

31. A rigid bar is suspended by three rods made of the same material as shown in the figure. The area and length of the central rod are $3A$ and L , respectively while that of the two outer rods are $2A$ and $2L$ respectively. If a downward force of 50 kN is applied to the rigid bar, the forces in the central and each of the outer rods will be
- (A) 16.67 kN each (C) 30 kN and 10 kN
 (B) 30 kN and 15 kN (D) 21.4 kN and 14.3 kN
32. The maximum and minimum shear stresses in a hollow circular shaft of outer diameter 20 mm and thickness 2 mm , subjected to a torque of 92.7 N.m will be
- (A) 59 MPa and 47.2 MPa (C) 118 MPa and 160 MPa
 (B) 10 MPa and 80 MPa (D) 200 MPa and 160 MPa
33. The shear stress at the neutral axis in a beam of triangular section with a base of 40 mm and height of 20 mm , subjected to a shear force of 3 kN is
- (A) 3 MPa (C) 10 MPa
 (B) 6 MPa (D) 20 MPa
34. U_1 and U_2 are the strain energies stored in a prismatic bar due to axial tensile forces P_1 and P_2 respectively. The strain energy stored in the same bar due to combined action of P_1 and P_2 will be
- (A) $U = U_1 + U_2$ (C) $U < U_1 + U_2$
 (B) $U = U_1 U_2$ (D) $U > U_1 + U_2$
35. The right triangular truss is made of members having equal cross sectional area of 1550 mm^2 and Young's modulus of $2 \times 10^5 \text{ MPa}$. The horizontal deflection of the joint Q is

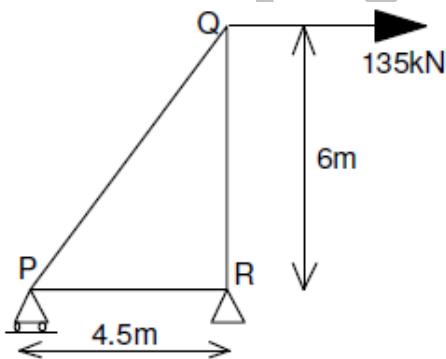

- (A) 2.47 mm (C) 14.1 mm
 (B) 10.25 mm (D) 15.68 mm
36. The influence line diagram (ILD) shown is for the member

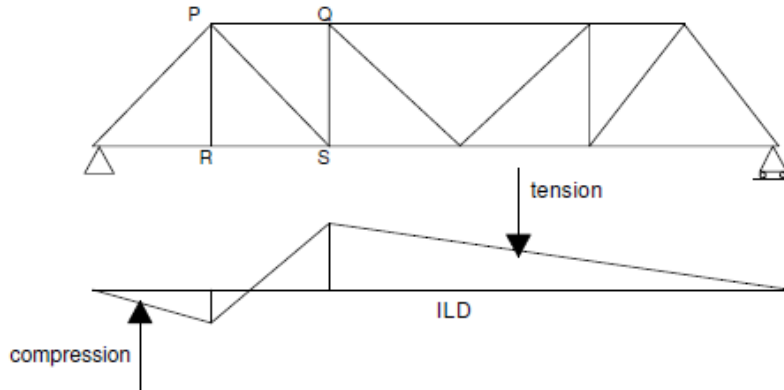

- (A) PS
(B) RS
(C) PQ
(D) QS

37. Consider the following statements:

1. The compressive strength of concrete decreases with increase in water-cement ratio of the concrete mix.
2. Water is added to the concrete mix for hydration of cement and workability.
3. Creep and shrinkage of concrete are independent of the water-cement ratio in the concrete mix.

The true statements are

- (A) 1 and 2
(B) 1, 2 and 3
(C) 2 and 3
(D) only 2
38. The percentage loss of prestress due to anchorage slip of 3mm in a concrete beam of length 30m which is post-tensioned by a tendon with an initial stress of 1200 N/mm^2 and modulus of elasticity equal to $2.1 \times 10^5 \text{ N/mm}^2$ is
- (A) 0.0175
(B) 0.175
(C) 1.75
(D) 17.5
39. A concrete beam of rectangular cross-section of size 120mm (width) and 200mm (depth) is prestressed by a straight tendon to an effective force of 150kN at an eccentricity of 20mm (below the centroidal axis in the depth direction). The stresses at the top and bottom fibres of the section are
- (A) 2.5 N/mm^2 (compression), 10 N/mm^2 (compression)
(B) 10 N/mm^2 (tension), 3.75 N/mm^2
(C) 3.75 N/mm^2 (tension), 3.75 N/mm^2 (compression)
(D) 2.75 N/mm^2 (compression), 3.75 N/mm^2 (compression)

40. Consider the following statements:

- I. Modulus of elasticity concrete increases with increases in compressive strength of concrete.
- II. Brittleness of concrete increases with decrease in compressive strength of concrete.
- III. Shear strength of concrete increases with increase in compressive strength of concrete.

The TRUE statements are

- (A) II and III
- (B) I, II and III
- (C) I and II
- (D) I and III

41. A steel flat of rectangular section of size 70×6 mm is connected to a gusset plate by three bolts each having a shear capacity of 15 kN in holes having diameter 11.5 mm. If the allowable tensile stress in the flat is 150 MPa, the maximum tension that can be applied to the flat is

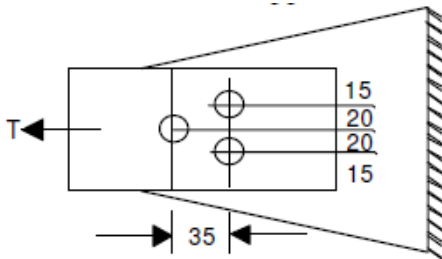

- (A) 42.3 kN
- (B) 52.65 kN
- (C) 59.5 kN
- (D) 63.0 kN

42. A bracket connection is made with four bolts of 10mm diameter and supports a load of 10kN at an eccentricity of 100mm. The maximum force to be resisted by any bolt will be

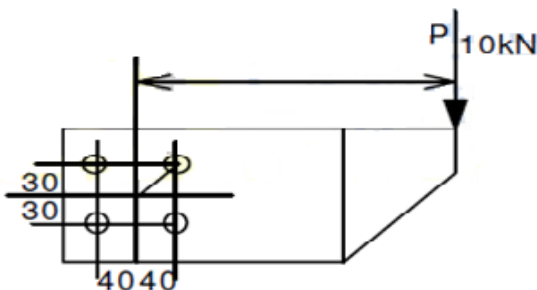

- (A) 5kN
- (B) 6.5kN
- (C) 6.8kN
- (D) 7.16kN

43. The plastic collapse load W_p for the propped cantilever supporting two point loads as shown in the figure in terms of plastic moment capacity, M_p is given by

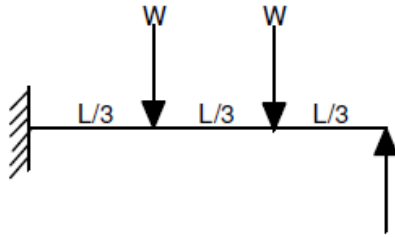

- (A) $3 M_P/L$ (C) $5 M_P/L$
 (B) $4 M_P/L$ (D) $6 M_P/L$
44. Sieve analysis on a dry soil sample of mass 1000g showed that 980g and 270g of soil pass through 4.75mm and 0.075mm sieve, respectively. The liquid limit and plastic limits of the soil fraction passing through 425 μ sieves are 40% and 18% respectively. The soil may be classified as
 (A) SC (C) CI
 (B) MI (D) SM
45. The water content of a saturated soil and the specific gravity of soil solids were found to be 30% and 2.70, respectively. Assuming the unit weight of water to be 10kN/m^3 , the saturated unit weight (kN/m^3), and the void ratio of the soil are
 (A) 19.4, 0.81 (C) 19.4, 0.45
 (B) 18.5, 0.30 (D) 18.5, 0.45
46. The factor of safety of an infinite soil slope shown in the figure having the properties $c = 0$, $c = 0$, $\phi = 35^\circ$, $\gamma_{dry} = 16\text{kN/m}^3$ and $\gamma_{sat} = 20\text{kN/m}^3$ is approximately equal to

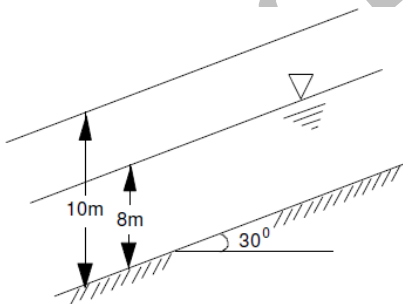

- (A) 0.70 (C) 1.00
 (B) 0.80 (D) 1.20
47. Match the following groups

Group – I

- P Constant head permeability test
 Q Consolidation test
 R Pycnometer test
 S Negative skin friction

Group – II

1. Pile foundations
 2. Specific gravity
 3. Clay soil
 4. Sand

- (A) P – 4, Q – 3, R – 2, S – 1
 (B) P – 4, Q – 2, R – 3, S – 1

- (C) P – 3, Q – 4, R – 2, S – 1
 (D) P – 4, Q – 1, R – 2, S – 3

48. The bearing capacity of a rectangular footing of plan dimensions $1.5\text{m} \times 3\text{m}$ resting on the surface of a sand deposit was estimated as 600 kN/m^2 when the water table is far below the base of the footing. The bearing capacities in kN/m^2 when the water level rises to depths of 3m, 1.5m and 0.5m below the base of the footing are
- (A) 600, 600, 400
 (B) 600, 450, 350
 (C) 600, 500, 250
 (D) 600, 400, 250
49. What is the ultimate capacity in kN of the pile group shown in the figure assuming the group to fail as a single block?

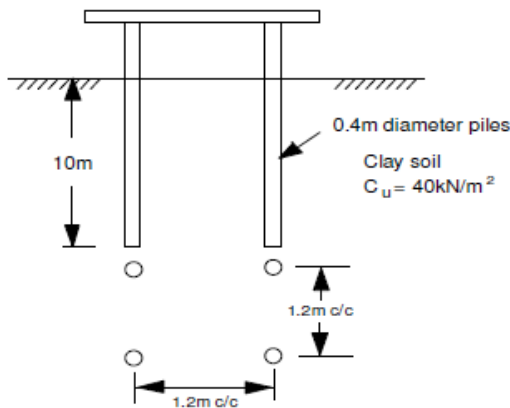

- (A) 921.6
 (B) 1177.6
 (C) 2438.6
 (D) 3481.6
50. A horizontal water jet with a velocity of 10m/s and cross sectional area of 10 mm^2 strikes a flat plate held normal to the flow direction. The density of water is 1000 kg/m^3 . The total force on the plate due to the jet is
- (A) 100N
 (B) 10N
 (C) 1N
 (D) 0.1N

51. A 1:50 scale model of a spillway is to be tested in the laboratory. The discharge in the prototype is $1000\text{m}^3/\text{s}$. The discharge to be maintained in the model test is
- (A) $0.057\text{m}^3/\text{s}$ (C) $0.57\text{m}^3/\text{s}$
 (B) $0.08\text{m}^2/\text{s}$ (D) $5.7\text{m}^3/\text{s}$
52. A triangular open channel has a vertex angle of 90° and carries flow at a critical depth of 0.30m . The discharge in the channel is
- (A) $0.08\text{m}^3/\text{s}$ (C) $0.15\text{m}^3/\text{s}$
 (B) $0.11\text{m}^3/\text{s}$ (D) $0.2\text{m}^3/\text{s}$
53. Flow rate of a fluid (density = $1000\text{kg}/\text{m}^3$) in a small diameter tube is $800\text{m}^3/\text{s}$. The length and the diameter of the tube are 2m and 0.5mm , respectively. The pressure drop in 2m length is equal to 2.0MPa . The viscosity of the fluid is
- (A) $0.025\text{N}\cdot\text{s}/\text{m}^2$ (C) $0.0092\text{N}\cdot\text{s}/\text{m}^2$
 (B) $0.012\text{N}\cdot\text{s}/\text{m}^2$ (D) $0.00102\text{N}\cdot\text{s}/\text{m}^2$
54. The flow rate in a wide rectangular open channel is $2.0\text{m}^3/\text{s}$ per meter width. The channel bed slope is 0.002 . The Manning's roughness coefficient is 0.012 . The slope of the channel is classified as
- (A) Critical (C) Mild
 (B) Horizontal (D) Steep
55. The culturable command area for a distributary channel is $20,000$ hectares. Wheat grown in the entire area and the intensity of irrigation is 50% . The kor period for wheat is 30 days and the kor water depth is 120mm . The outlet discharge for the distributary should be
- (A) $2.85\text{m}^3/\text{s}$ (C) $4.63\text{m}^3/\text{s}$
 (B) $3.21\text{m}^3/\text{s}$ (D) $5.23\text{m}^3/\text{s}$

56. An isolated 4-hour storm occurred over a catchment as follows

Time	1 st hour	2 nd hour	3 rd hour	4 th hour
Rainfall (mm)	9	28	12	7

The ϕ index for the catchment is $10\text{mm}/\text{h}$. The estimated runoff depth from the catchment due to the above storm is

- (A) 10mm (C) 20mm
 (B) 16mm (D) 23mm

57. Two electrostatic precipitators (ESPs) are in series. The fractional efficiencies of the upstream and downstream ESPs for size d_p are 80% and 65%. Respectively. What is the overall efficiency of the system for the same d_p ?
- (A) 100% (C) 80%
(B) 93% (D) 65%
58. 50g of CO_2 and 25g of CH_4 are produced from the decomposition of municipal solid waste (MSW) with a formula weight of 120g. What is the average per capita green house gas production in a city of 1 million people with a MSW production rate of 500 ton / day?
- (A) 104 g/day (C) 208 g/day
(B) 120 g/day (D) 313 g/day
59. The extra widening required for a two-lane national highway at a horizontal curve of 300 m radius, considering a wheel base of 8m and a design speed of 100kmph is
- (A) 0.42m (C) 0.82m
(B) 0.62m (D) 0.92m
60. While designing a hill road with a ruling gradient of 6%, if a sharp horizontal curve of 50m radius is encountered, the compensated gradient at the curve as per the Indian Roads Congress specifications should be
- (A) 4.4% (C) 5.0%
(B) 4.75% (D) 5.25%
61. The design speed on a road is 60kmph. Assuming the driver reaction time of 2.5 seconds and coefficient of friction of pavement surface as 0.35, the required stopped distance for two-way traffic on a single lane road is
- (A) 82.1m (C) 164.2m
(B) 102.4 (D) 186.4m
62. The width of the expansion joint is 20mm in a cement concrete pavement. The laying temperature is 20°C and the maximum slab temperature in summer is 60°C . The coefficient of thermal expansion of concrete is 10×10^{-6} mm/mm/ $^\circ\text{C}$ and the joint filler compresses upto 50% of the thickness. The spacing between expansion joints should be
- (A) 20m (C) 30m
(B) 25m (D) 40m
63. The following data pertains to the number of commercial vehicles per day for the design of a flexible pavement for a national highway as per IRC: 37-1984

67. The following measurements were made during testing a leveling instrument.

Instrument at	Staff Reading at	
	P_1	Q_1
P	2.800m	1.700m
Q	2.700m	1.800m

P_1 is close P and Q_1 is close to Q. If the reduced level of station P is 100.000m, the reduced level of station Q is

- (A) 99.000m (C) 101.000m
 (B) 100.000m (D) 102.000m
68. Two straight lines intersect at an angle of 60° . The radius of a curve joining the two straight lines is 600m. The length of long chord and mid-ordinates in metres of the curve are
- (A) 80.4, 600.00 (C) 600.0, 39.89
 (B) 600.0, 80.4 (D) 40, 89,300
69. The magnetic bearing of a line AB is $S 45^\circ E$ and the declination is 5° West. The true bearing of the line AB is
- (A) $S 45^\circ E$ (C) $S 50^\circ E$
 (B) $S 40^\circ E$ (D) $S 50^\circ W$

COMMON DATA QUESTIONS

Common Data for Questions 70 and 71

Water is flowing through the permeability apparatus as shown in the figure. The coefficient of permeability of the soil is km/s and the porosity of the soil sample is 0.50.

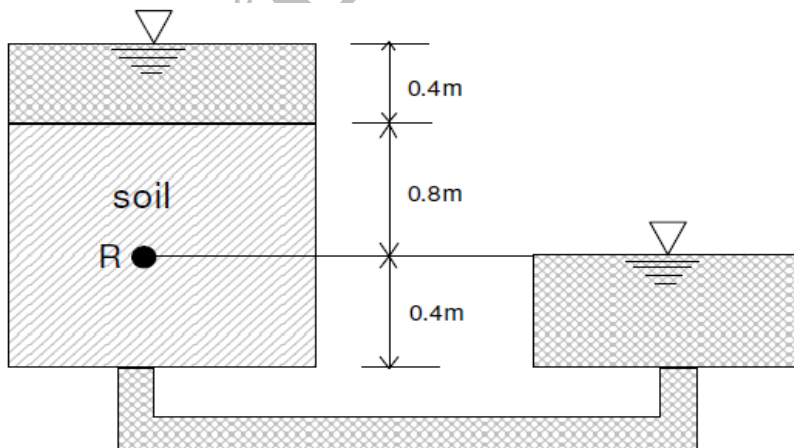

70. The total head, elevation head and pressure head in metres of water at the point R shown in the figure are
- (A) 0.8, 0.4, 0.4
(B) 1.2, 0.4, 0.8
(C) 0.4, 0, 0.4
(D) 1.6, 0.4, 1.2
71. What are the discharge velocity and seepage velocity through the soil sample?
- (A) k , $2k$
(B) $2/3k$, $4/3k$
(C) $2k$, k
(D) $4/3k$, $2/3k$

Common Data for Questions 72 and 73:

Ordinates of a 1 – hour unit hydrograph at 1 hour intervals, starting from time $t = 0$, are 0, 2, 6, 4, 2, 1 and $0 \text{ m}^3/\text{s}$.

72. Catchment area represented by this unit hydrograph is
- (A) 1.0 km^2
(B) 2.0 km^2
(C) 3.2 km^2
(D) 5.4 km^2
73. Ordinate of a 3-hour unit hydrograph for the catchment at $t = 3$ hours is
- (A) $2.0 \text{ m}^3/\text{s}$
(B) $3.0 \text{ m}^3/\text{s}$
(C) $4.0 \text{ m}^3/\text{s}$
(D) $5.0 \text{ m}^3/\text{s}$

Common Data for Questions 74 and 75:

A completely mixed activated sludge process is used to treat a wastewater flow of 1 million liters per day (1 MLD) having a BOD_5 of 200 mg/L . The biomass concentration in the aeration tank is 2000 mg/L and the concentration of the net biomass leaving the system of 50 mg/L . The aeration tank has a volume of 200 m^3 .

74. What is the hydraulic retention time of the wastewater in aeration tank?
- (A) 0.2h
(B) 4.8h
(C) 10h
(D) 24h
75. What is the average time for which the biomass stays in the system?
- (A) 5 h
(B) 8 h
(C) 2 days
(D) 8 days

Linked Answer Questions: Q.76 to Q.85 carry TWO marks each

Statement for Linked Answer Questions 76 and 77:

A two span continuous beam having equal spans each of length L is subjected to a uniformly distributed load ω per unit length. The beam has constant flexural rigidity.

76. The reaction at the middle support is

- (A) ωL (C) $\frac{5\omega L}{4}$
(B) $\frac{5\omega L}{2}$ (D) $\frac{\omega L^2}{16}$

77.

Statement for Linked Answer Questions 78 and 79:

A singly reinforced rectangular concrete beam has a width of 150mm and an effective depth of 330mm. The characteristic compressive strength of concrete is 20MPa. Adopt the stress block for concrete as given in IS 456-2000 and take limiting value of depth of neutral axis as 0.48 times the effective depth of the beam.

78. The limiting value of the moment of resistance of the beam is kN.m is

- (A) 0.14 (C) 45.08
(B) 0.45 (D) 156.82

79. The limiting area of tension steel in mm^2 is

- (A) 473.9 (C) 373.9
(B) 412.3 (D) 312.3

Statement for Linked Answer Questions 80 and 81:

The ground conditions at a site are as shown in the figure. The water table at the site which was initially at a depth of 5m below the ground level got permanently lowered to a depth of 15m below the ground level due to pumping of water over a few years. Assume the following data

- i. unit weight of water = 10kN/m^3
- ii. unit weight of sand above water table = 18kN/m^3
- iii. unit weight of sand and clay below the water table = 20kN/m^3
- iv. coefficient of volume compressibility = $0.25\text{m}^2/\text{MN}$

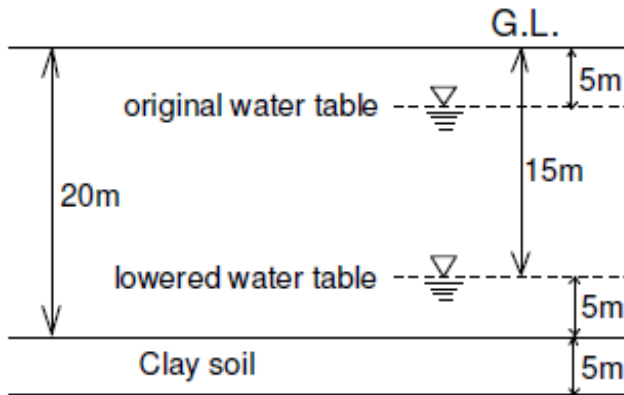

80. What is the change in the effective stress in kN/m^2 at mid-depth of the clay layer due to the lowering of the water table ?
- (A) 0 (C) 80
(B) 20 (D) 100
81. What is the compression of the clay layer in mm due to the lowering of the water table ?
- (A) 125 (C) 25
(B) 100 (D) 0

Statement for Linked Answer Questions 82 and 83:

A rectangular open channel needs to be designed to carry a flow of $2.0 \text{ m}^3/\text{s}$ under uniform flow conditions. The Manning's roughness coefficient is 0.018. The channel should be such that the flow depth is equal to half the width, and the Froude number is equal to 0.5.

82. The red slope of the channel to be provided is
- (A) 0.0012 (C) 0.0025
(B) 0.0021 (D) 0.0052
83. Keeping the width, flow depth and roughness the same, if the bed slope of the above channel is doubled, the average, boundary shear stress under uniform flow conditions is
- (A) 5.6 N/m^2 (C) 12.3 N/m^2
(B) 10.8 N/m^2 (D) 17.2 N/m^2

Statement for Linked Answer Questions 84 and 85:

A plain sedimentation tank with a length of 20m, width of 10m, and a depth of 3m is used in a water treatment plant to treat 4 million litres of water per day (4 MLD). The average temperature

of water is 20°C . The dynamic viscosity of water is $1.002 \times 10^{-3} \text{ N.s/m}^2$ at 20°C . Density of water is 998.2 kg/M^3 . Average specific gravity of particles is 2.65.

84. What is the surface overflow rate in the sedimentation tank ?

(A) $20\text{m}^3 / \text{m}^2 / \text{day}$

(C) $67\text{m}^3 / \text{m}^2 / \text{day}$

(B) $40\text{m}^3 / \text{m}^2 / \text{day}$

(D) $133\text{m}^3 / \text{m}^2 / \text{day}$

85. What is the minimum diameter of the particle which can be removed with 100% efficiency in the above sedimentation tank ?

(A) $11.8 \times 10^{-3} \text{ mm}$

(C) $50 \times 10^{-3} \text{ mm}$

(B) $16.0 \times 10^{-3} \text{ mm}$

(D) $160 \times 10^{-3} \text{ mm}$

